

### NTM SERIES TWIN MOTORS RANGE HOOD



The NTM Series Twin Motors Range Hood meets the professional cooking needs of the serious at home chef. Its rounded edges and sleek design compliments any modern decor.

#### FEATURES

- 3-speed control panel with easy push button controls
- Rounded edges for contemporary look
- Smooth surfaces and fully enclosed underside make cleaning easy
- Enclosed 120 V 40 W appliance bulb illuminates cooking surface (bulb not included)
- Grease capture design system includes grease pan and two grease guard cups that remove quickly for cleaning
- Unit has 3-ducting options - 3 1/4" x 10" (83 mm x 254 mm) horizontal - vertical and 6" (152 mm) round vertical (dampers and adapters included)
- Triple speed twin fan motors
- Available in 30" width, white and stainless steel

1 year warranty

#### TYPICAL SPECIFICATION

The Range Hood shall be NuTone NTM Series.

It shall be available in a 30" (762 mm) width. The Range Hood shall be available in a white finish and a stainless steel finish.

Unit shall have a built-in back draft damper and be ducted to exterior of dwelling either horizontally or vertically.

Unit shall have three fan speed push-button controls, a light push-button control and an on/off push-button control.

Unit shall have 2 triple speed fan motors.

Maximum air delivery shall be no less than 500 CFM (236 L/s) and sound levels no greater than 4.1 Sones (3 1/4" x 10" vertical discharge). All air and sound ratings shall be certified by HVI.

Units shall be CSA certified.



HVI-2100 CERTIFIED RATINGS comply with new testing technologies and procedures prescribed by the Home Ventilating Institute, for off-the-shelf products, as they are available to consumers. Product performance is rated at 0.1 in. (2.54 mm) static pressure, based on tests conducted in AMCA's state-of-the-art test laboratory. Sones are a measure of humanly-perceived loudness, based on laboratory measurements.



Broan-NuTone Canada Inc., 1140 Tristar Drive, Mississauga, Ontario, Canada L5T 1H9 (1-888-882-7626)

REFERENCE	QTY.	REMARKS	Project
			Location
			Architect
			Engineer
			Contractor
			Submitted by <span style="float: right;">Date</span>

# PERFORMANCE RATINGS ——— NTM SERIES TWIN MOTORS RANGE HOOD

## SPECIFICATIONS

VOLTS	AMPS	Max. CFM (L/s)	SONES Normal Setting	DUCT (mm)
120	2.0	500 (236)	4.1	3-1/4" x 10" (83 mm x 254 mm) OR 6" (152 mm) Round

## DIMENSIONS

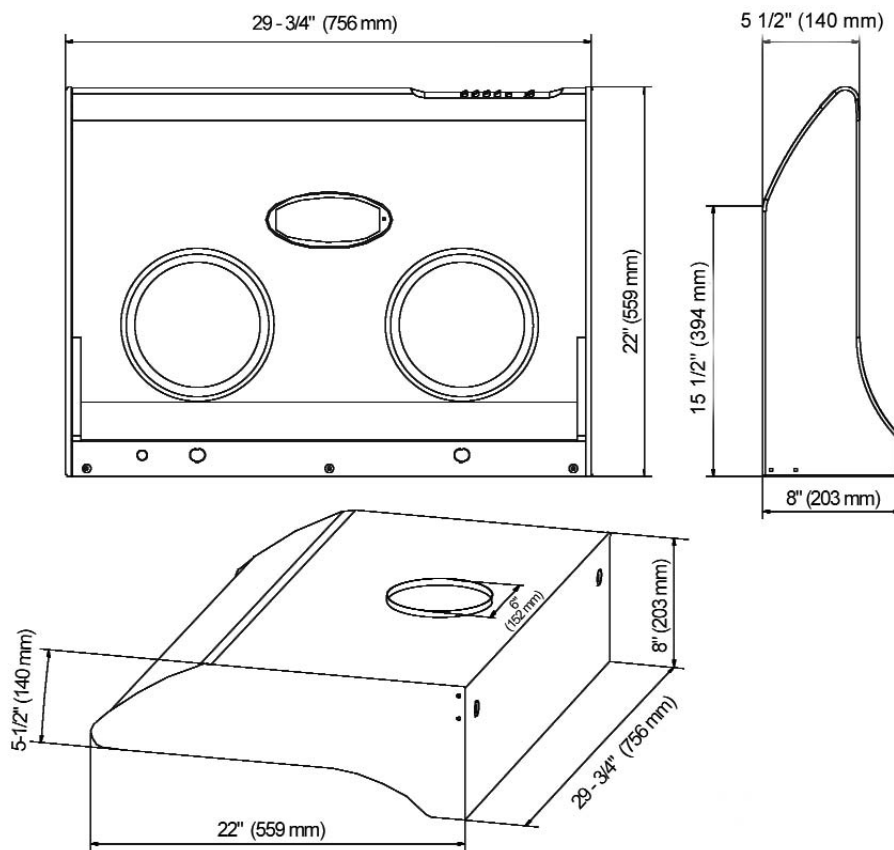

## MODELS AVAILABLE

SIZE	WHITE	STAINLESS STEEL
30"	NTM30WH	NTM30SS



HVI-2100 CERTIFIED RATINGS comply with new testing technologies and procedures prescribed by the Home Ventilating Institute, for off-the-shelf products, as they are available to consumers. Product performance is rated at 0.1 in. (2.54 mm) static pressure, based on tests conducted in AMCA's state-of-the-art test laboratory. Sones are a measure of humanly-perceived loudness, based on laboratory measurements.

